

SOUDAFRAME^{SWI}

SOUDAL

THE PRE-WALL INSTALLATION SYSTEM



PLANNING, INSTALLATION AND SEALING
Easier, faster and safer!

The pre-wall window installation system

PLANNING, INSTALLATION AND SEALING - Easier, faster and safer!

SODAL **BUILD THE FUTURE**

For many years SODAL has been offering a comprehensive range of high quality products for the assembly of windows and doors.

Our research and development department in the new R&D center with more than 30 highly trained employees, constantly develops and optimizes existing products and, in co-operation with the market, develops new, even more powerful products for innovative solutions.

External testing institutes support us and constantly monitor our products as well as their production. System checks and regular external monitoring ensure a consistently high level of quality consistency. Our consultants are happy to assist you with professional processing recommendations and individual object support.



EXPERTS IN SEALINGS, ADHESIVES & PU FOAMS

Sodal is Europe's leading independent manufacturer of adhesives, sealants and pu-foams. Founded in 1966, the company is still 100% family owned. With innovative products Sodal offers solutions for sealing, bonding and filling applications. Our products are used in construction, industry and do it yourself. The Sodal Group employs over 3,000 people worldwide, more than

a third of them at its headquarters in Turnhout, Belgium. Sodal operates in over 65 countries on every continent in the world and exports its products to over 130 countries worldwide. In 2018, the company generated sales of approximately EUR 820 million.

www.sodal.com

THERMAL INSULATION & ENERGY SAVING REGULATION

The energy performance of buildings is based on European legislation, in particular the original directive 2002/91/EC, also called the EPBD. This directive was in line with the “20-20-20 targets” of the European Union:

- Reduction of CO₂ gas emissions by 20%
- Reduction of energy consumption by 20%
- Increased share of renewable energy to 20%
(reference year: 1990)

Because the current path could not ensure a 20% reduction in energy consumption by 2020, Europe created the 2012/27/EC Directive. This directive covers the general subject “energy efficiency” and came into effect in December 2012. It mainly affects existing houses and buildings.

The recast of the energy performance directive (2010/31/EC) included not only stricter requirements for new buildings and renovations, and a stronger role for the energy performance certificate, but also the introduction of the term NZEB (Nearly Zero Energy Building). As from 2021, this will be the standard for all newly built houses in the whole of Europe! As this European legislation has been set out in a Directive, the member states will have to convert this European policy into national legislation and integrate it into local energy policies.

AIRTIGHTNESS

As the insulation of houses is improving the importance of ventilation is increasing with regard to energy loss. Part of this loss is caused by the infiltration and exfiltration of air through materials and openings in the building envelope. To limit this loss, the aim is to achieve good ‘airtightness’ of the building’s envelope, which will also reduce the risk of damage and draft.

THERMAL BRIDGES & JOINTS

In many European countries, the energy performance calculation must take into consideration any thermal bridges (cold bridges) in a building. This is quite logical as poorly executed building knots may lead to large transmission losses resulting in an average heat loss of 5% (for an average house). Designers must therefore pay attention to joints, especially joints between various construction elements. Window-to-wall joints, for example, are important potential thermal bridges, which easily amount to 100 meters for an average house.







In recent years, the requirements for energy efficiency new buildings have been gradually become more strict. Today's requirements require a high level of insulation. For optimum thermal performance, windows should be installed into the insulation layer. The better the insulation, the thicker the insulation layer must be, and the greater the distance between the window and the supporting wall.

For fixing windows usually metal wall brackets are used. Depending on the distance to the load-bearing inner wall, these brackets must correspondingly be heavier (and stronger). However, increasing the metal content increases the thermal conductivity, and thereby also the risk of thermal bridges and its undesired consequences (mold and moisture problems).

SOUDAFRAME SWI (Soudal Window Installation) is a cleverly designed pre-wall system with a very low thermal conductivity for the installation of exterior joinery, made from glass fiber reinforced plastic (GFRP).

The system consists of L-shaped frame elements, which can easily be assembled to a complete pre-frame using the plug-in connection pieces. A special adhesive which bonds and seals at the same time (for an air- and watertight installation of the

subframe to the wall) and spring clips for an easy adjustment and fixation of the window frame in the pre-frame.

The window frame is directly installed in the SOUDAFRAME SWI pre-frame, without the need of a metal connection between the window frame and the loadbearing wall construction. In other words a thermally optimal window installation, without thermal bridges.

The very slim L-shaped frame elements enable a good connection with the insulating layer. This maximizes the surface area of the insulation layer and, as a result, improves the overall thermal performance of the building envelope. SOUDAFRAME SWI creates in a single way a standardized installation, by always providing a custom-fit, dimensionally accurate, straight and square pre-frame with uniform joint dimensions, regardless of the building surface. This considerably simplifies all work steps in the assembly and sealing processes, which will also result in fewer errors and a faster installation at a higher quality.

The system can be used universally for all common window profiles and materials and is available in various sizes.



SOUDAFRAME SWI (Soudal Window Installation) is a pre-wall system for the installation of exterior joinery, made of glass fiber reinforced plastic (GFRP).

GFRP as a composite material, mainly consists of two components: glass fibers as a mechanical reinforcement (absorption of tensile forces) and a reaction resin as a matrix for embedding the fibers (compressive forces). An unique feature of GFRP is that the material can be prepared to match the specific requirements of the application. With the GFRP frame elements of the SoudaFrame SWI system Soudal has made optimum use of the many advantages of GFRP and thus creating the right material for the application.



SWI SOUDAFRAME



As an efficient and innovative plastic material, fiber composites have been used for decades in a variety of industries and applications - from aerospace, automotive and rail to furniture and cycling industry. In construction, composites are mainly used in applications where the combination of its superior material properties is required: where high load-bearing capacities are required, where high thermal insulation requirements are set, which must also be corrosion and weather resistant and which offer high strength and form stability (no shrinkage or expansion) in combination with low weight. That is what GFRP can be.

The production process of the GFRP frame elements is environmentally friendly and energy efficient. As a waste product, GFRP is fully recyclable and is mainly reused in cement production.

Components

A perfect match for the best result

SYSTEM COMPONENTS

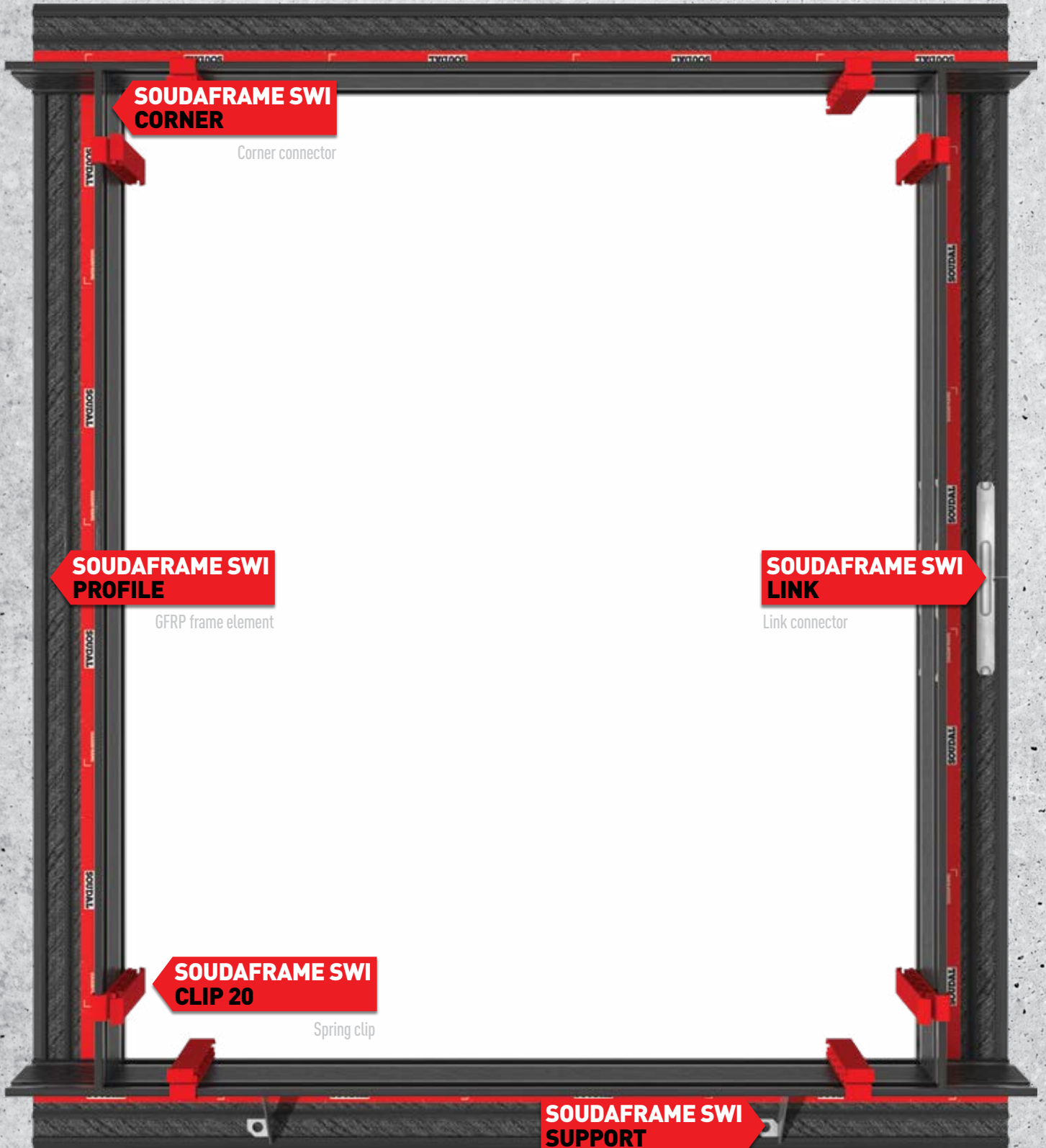

PROPERTIES

FEATURE

ADVANTAGE

PRACTICAL USE

SOUDAFRAME SWI PROFILE (GFRP FRAME ELEMENT)

- Low weight with high load-bearing capacity / high rigidity
- Good thermal performance due to low thermal conductivity
- Very low thermal expansion
- Easy drilling through the frame
- Optimal use of the frame length

- Enables to install large windows without additional support
- Low weight allows a 1-man assembly
- Zero cold bridges through the use of thin L-shaped GFRP profiles and the application of the facade insulation up to the profile edge for maximum thermal efficiency
- Uniform joint dimensions regardless of the temperature
- „Leftovers“ can be used up to a minimum length

SOUDAFRAME SWI PROFILE (PRE-ASSEMBLED FRAME)

- Simple, safe and error-free connection between the frame elements for a quick installation and sealing and high flexibility on the construction site
- High tack adhesive to mount and seal frame to the wall
- Pre-assembled frame
- Only adjust once for the entire frame

- Good sealing quality of the frame enables compliance with the RAL specifications for sealing windows
- Easy mounting and sealing of the frame with Soudaseal SWI hybrid adhesive (fewer plugs needed)
- Perfect fitting connectors quickly create a pre-assembled frame
- Assembly on site is possible
- Individual frame elements do not have to be attached, fixated and levelled separately

SOUDAFRAME SWI CLIP 20 (SPRING CLIP)

- 1 standard part for automatic fixing and easy alignment of the window frame in the subframe
- Uniform joint dimensions
- Reusable wedge

- Adjust the frame manually, even in case of a one-man installation
- No need for different sizes of wedges, one fits all
- No more stacking of multiple wedges
- The uniform circumferential joint dimensions enables an optimized, standardized joint sealing and improves the sealing quality

SOUDAFRAME SWI (INTEGRATED SYSTEM)

- All products of the Soudal Window System range are compatible with SOUDAFRAME SWI.
- Single source products for the installation and sealing of windows result in higher efficiency

- The integrated system creates easy, reliable and long-lasting quality, thus ensuring significant cost savings over the entire life cycle

COMPONENTS

A perfect match for the best result

SOUDAFRAME SWI **FRAME ELEMENT**

The SoudaFrame SWI forms the base of our pre-wall window installation system is the SOUDAFRAME SWI frame element. Made of high-quality GFRP, this innovative lightweight material offers a high load-bearing capacity combined with high rigidity.

Simple, safe and error-free to connect, the frame elements are a guarantee for fast assembly and high flexibility on the construction site. The elements are available in 4 dimensions (90, 130, 160 and 200 mm) with a length of 2,2 meters.



90 mm

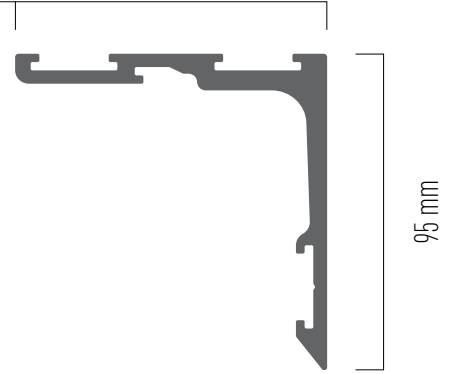

130 mm

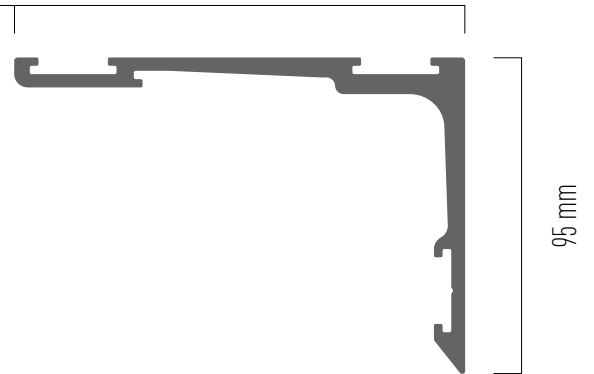

160 mm

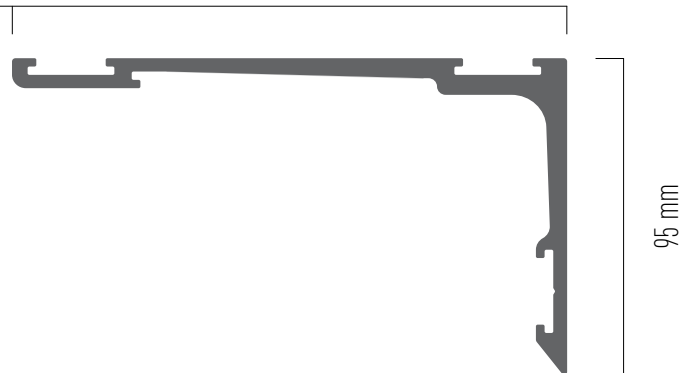

SOUDAFRAME SWI CLIP 20 ▶

200 mm

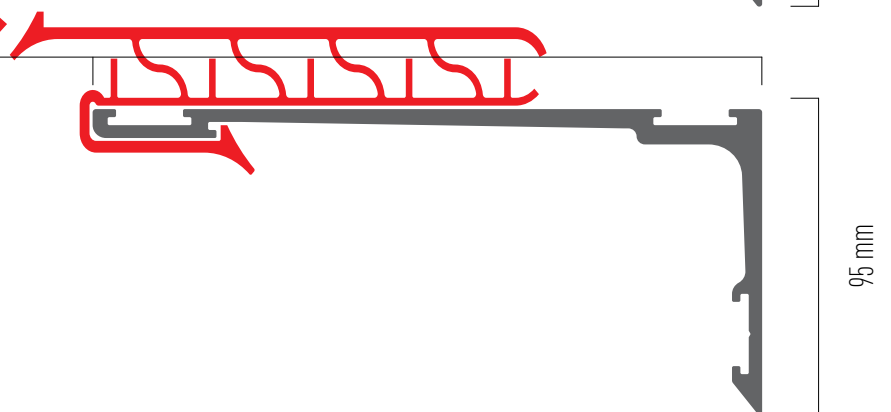

COMPONENTS

A perfect match for the best result

SYSTEM COMPONENTS

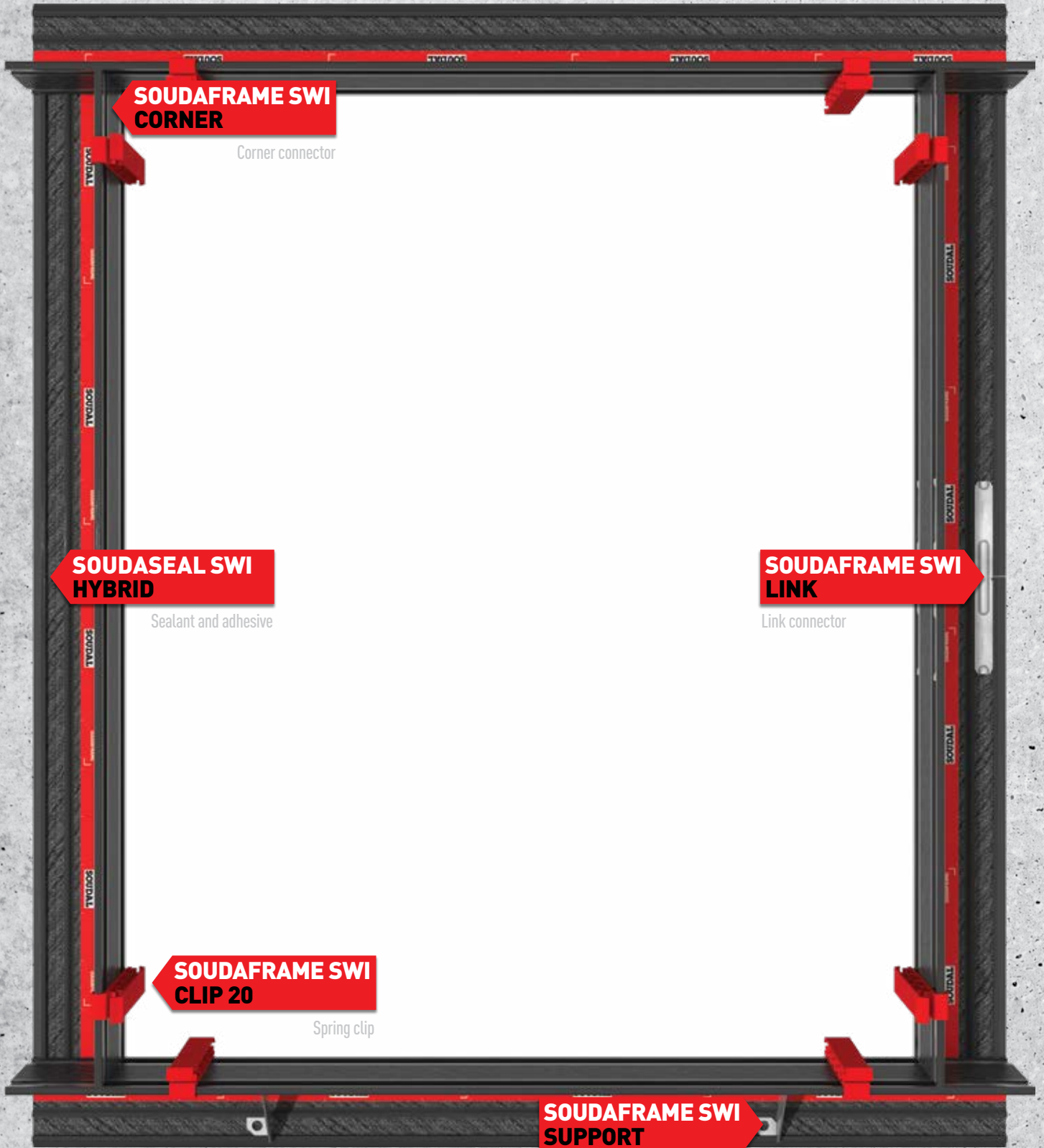



SOUDAFRAME SWI **CORNER**

High-quality metal connection piece for an easy, safe and error-free connection of the frame elements. The innovative plug-in solution enables a fast installation and high flexibility on the construction site.



SOUDAFRAME SWI **LINK**

Connector for extending frame elements at e.g. large windows, use of cut-off frame elements.

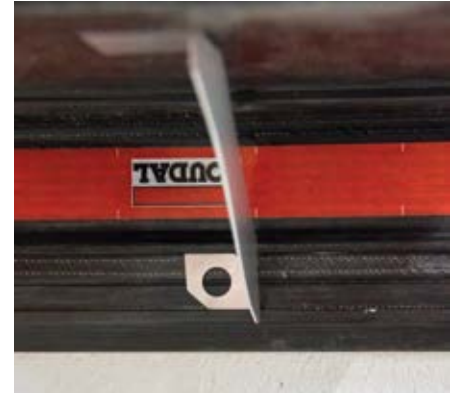

SOUDAFRAME SWI **SUPPORT**

Support bracket for increased load transfer for large and heavy windows as well as for sliding doors.



SOUDAFRAME SWI **CLIP 20**

Practical installation aid for an automatic fixation and easy alignment of the window frame in the subframe. The pressure of the spring clip holds the frame into place and allows easy adjustment by hand. No more hassle with looking for the right size wedge.



SOUDAFRAME SWI **HYBRID**

Elastic, one-component adhesive and sealant based on hybrid polymer with a very high initial tack. Soudaseal SWI was specially developed for bonding and air- and watertight sealing of the SoudaFrame SWI pre-wall window installation system.



SOUДАFRAMESM

SOU DAL

SOUДАFRAMESM

SOU DAL

PRE-WALL WINDOW INSTALLATION

EASY, SAFELY & FAST

**THE EASIEST
PRE-WALL
WINDOW
INSTALLATION
SYSTEM!**

INSTALLATION

The easiest window installation system!



01 Measure the window



02 Cut profiles to length



03 Insert the corner connector



04 Connect 2 frame element or cut-offs with the link connector

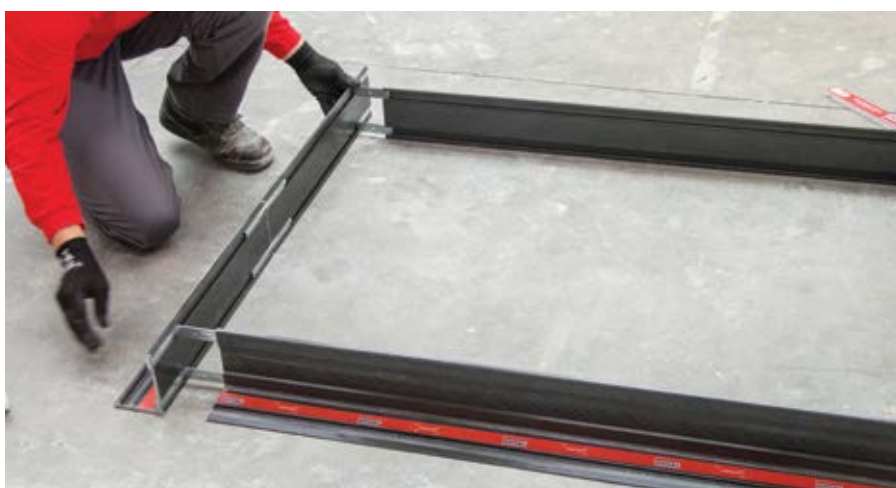

05 Assemble the complete frame



06 Clean the backend of the frame



07 Apply the adhesive to all connection joints



08 Apply the adhesive continuously, in 2 beads, onto the frame



09 Pick up the frame and press it against the wall while moving up and down, left to right



10 Align, adjust and done!

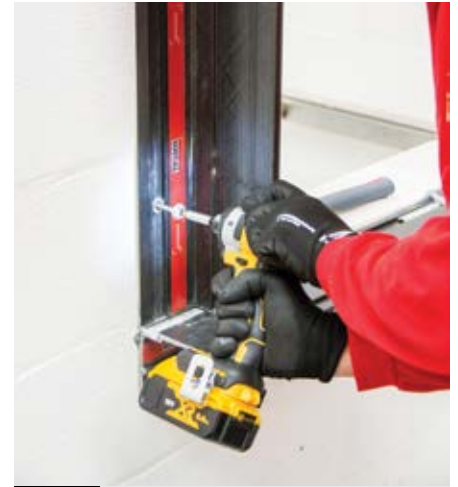

11 Fix the frame to the wall with the appropriate screws and plugs



12 Seal the inner corners and position the spring clip



13 Pre-drill the window, insert and align the window



14 Fix the windows mechanically



15 Remove spring clips and seal connection joint between frame and window



16 Seal on the inside with Soudatight LQ / SP



17 Seal with Soudatight Hybrid on the outside

INSTALLATION

The easiest window installation system!

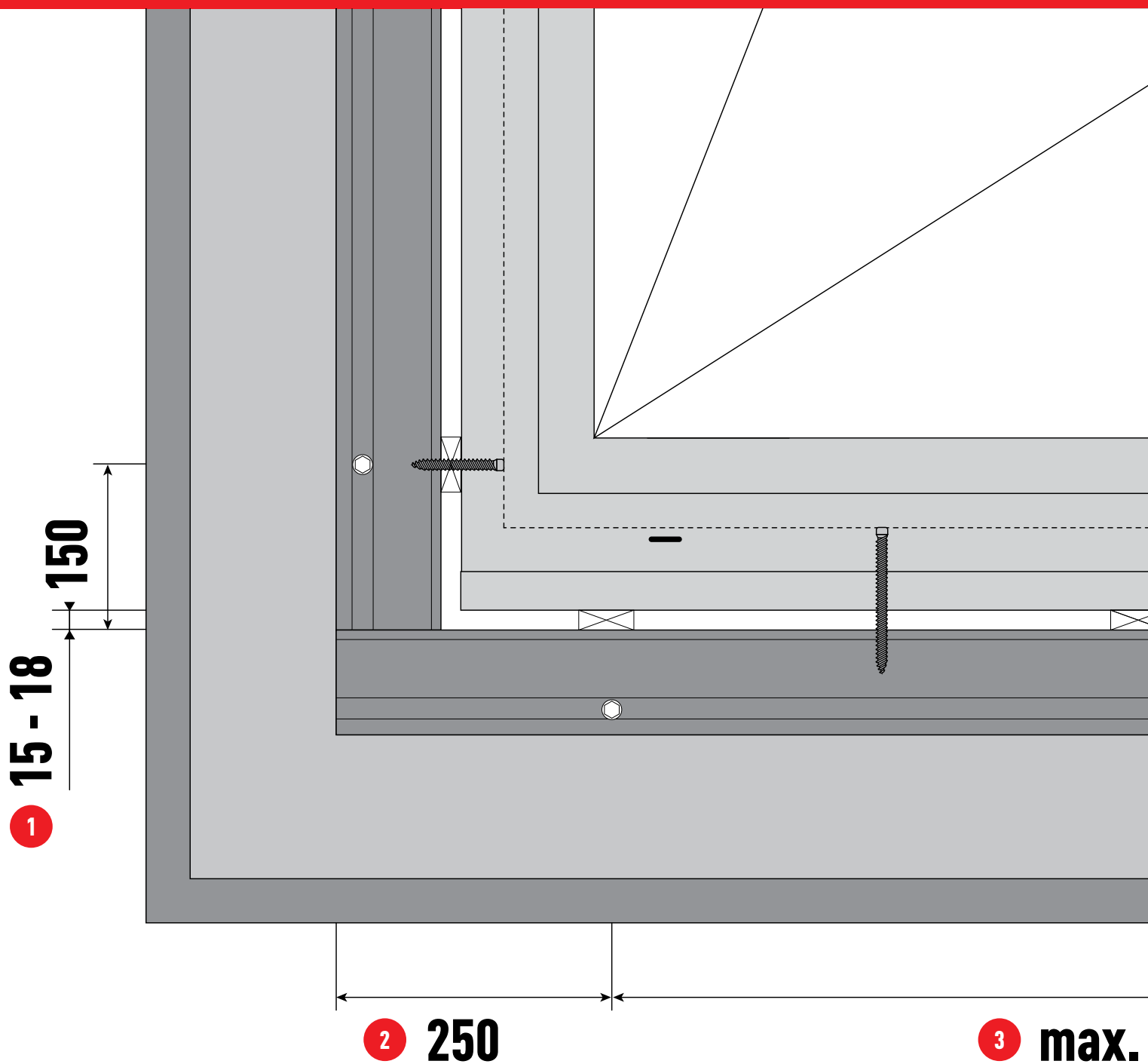

1 By using the spring clip, we create a circumferentially standardized joint connection of 15 - 18 mm. This pre-defined joint dimension enables an optimal planning of the necessary quantities of the products used for in- and outdoor sealing, before the actual installation and sealing of the windows.

2 The drill hole in the lower frame element is situated at 250 mm from the outer edge of this frame element. A special guidance notch helps to correctly fixate the frame to the wall.

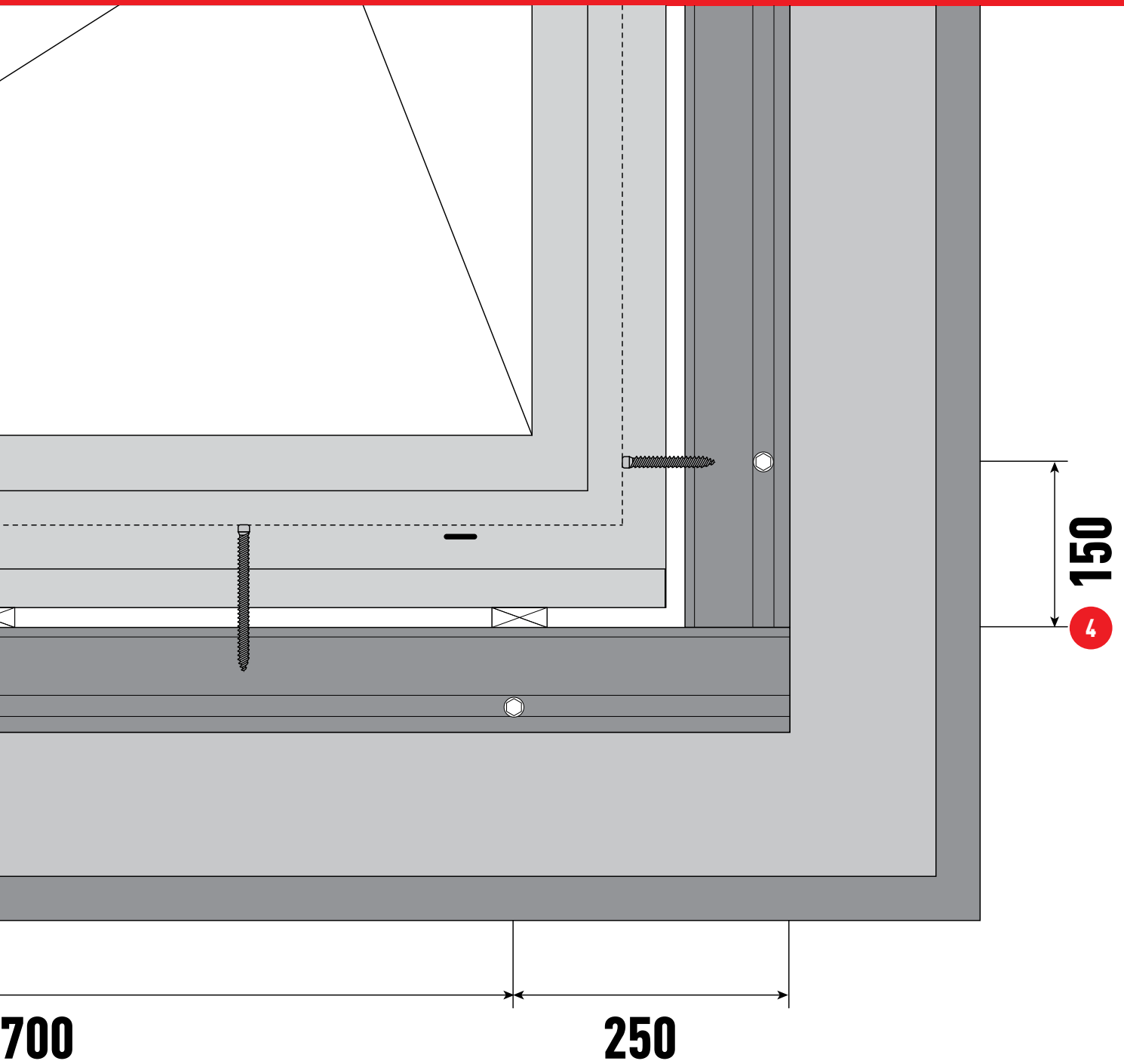

3 The maximum distance between the two drill holes is 700 mm. For longer profiles, additional drill holes could be necessary.

4 For the vertical frame elements the distance between the lower drill hole and bottom edge of the frame element is 150 mm. A special guidance notch helps to correctly fixate the frame to the wall.

TESTED AND CERTIFIED QUALITY

Trust is good, control is better!

IFT DIRECTIVE MO-01/1 Wall connection of windows, part 1

Testing the joint characteristics of a sealing system between window and building structure in new condition and after a series of simulated short-term exposures (=ageing)

Test report 17-002267-PR01-01

Sealing system between window,

pre-wall window installation system and building structure

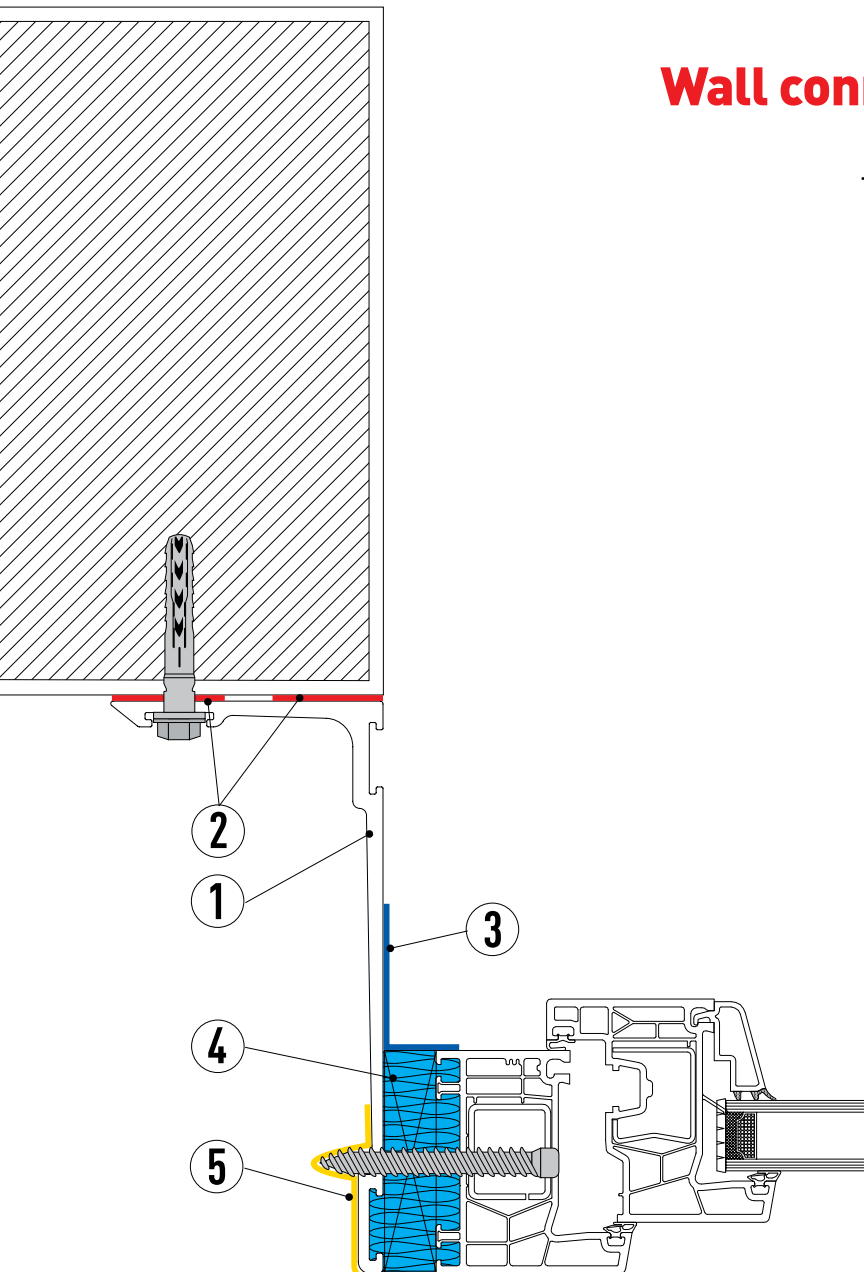

1. SoudaFrame SWI, 2. Soudaseal SWI, 3. Soudatight LQ/SP (GUN), 4. Flexifoam, 5. Soudatight Hybrid



MO-01

IFT DIRECTIVE MO-02/1

Wall connection of windows, part 2

Checking the function (and durability) of a mounting system between window and building structure in new condition, as well as after simulated short-term loading.

Test report 17-002267-PR01-02

Mounting system between window and building structure in pre-wall installation

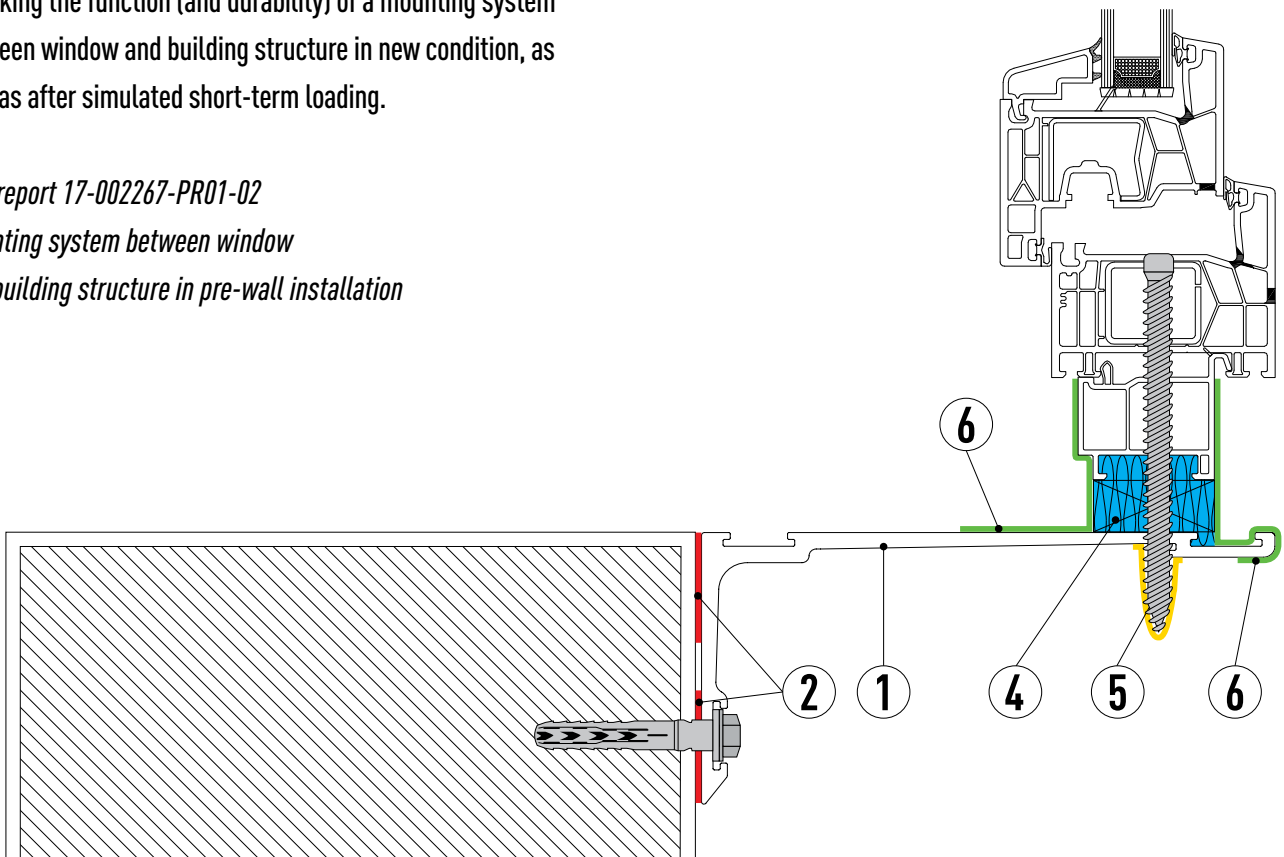

MO-02

CERTIFIED QUALITY

Trust is good, control is better!

TECHNICAL SPECIFICATIONS SOUDAFRAME SWI

SoudaFrame SWI was specially developed for the pre-wall installation of windows and doors in the insulating layer. The pre-wall window installation system consists of lightweight L-shaped frame elements made of glass fiber reinforced plastic (GFRP), metal corner connectors, extension pieces and

support elements (SWI Corner, SWI Link and SWI Support), a specially developed high tack adhesive (Soudaseal SWI) for an air- and waterproof installation and sealing of the frame to the wall, as well as SWI Clips that allow for an easy one-person installation and sealing with uniform joint dimensions.

TECHNICAL DATA	STANDARD/SIZE	PROPERTIES
Material	EN 13501-1	GFRP
Fire reaction class	EN13501-1 DIN 4102	Class E (normal flammability Classe B2)
Thermal conductivity (λ)		$\lambda = 0,125 \text{ W}/(\text{m}\cdot\text{K})$
Temperature resistance**		-40 °C → 90 °C
Application temperature		5 °C → 35 °C
Thickness		Variable (4 to 6 mm)
Weight/meter	90 mm	2,200 kg/m
	130 mm	2,583 kg/m
	160 mm	2,940 kg/m
	200 mm	3,322 kg/m
Ageing resistance		Excellent
Humidity resistance		Excellent
Chemical resistance		Excellent
Decay resistance		Excellent
Shear load window frame screws		FRK = 1,08 kN
Tensile load window frame screws		FRK = 1,17 kN
Load transfer	90 mm	≤ 787 kg/m (a)
	130 mm	≤ 629 kg/m (b)
		≤ 500 kg/m (b)
	200 mm	≤ 375 kg/m (b)
Fall protection		FRK, max = 3.87 kN (c)

These values may vary depending on environmental factors such as temperature, moisture, and type of substrates.

*** This information relates to fully cured product.*

(a) Values at 3 mm deformation, with a bonded and bolted frame, masonry: concrete C20/25.

(b) Values at 3 mm deformation, with a bonded and bolted frame incl. SoudaFrame SWI Support, masonry: concrete C20/25.

(c) Values with a window frame + screw in a frame of 200 mm incl. SoudaFrame SWI Support.

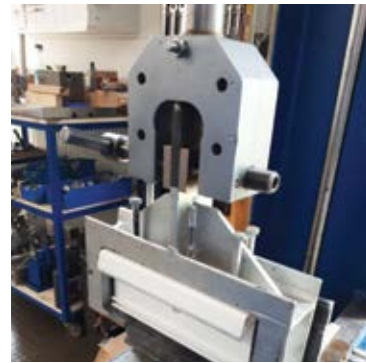
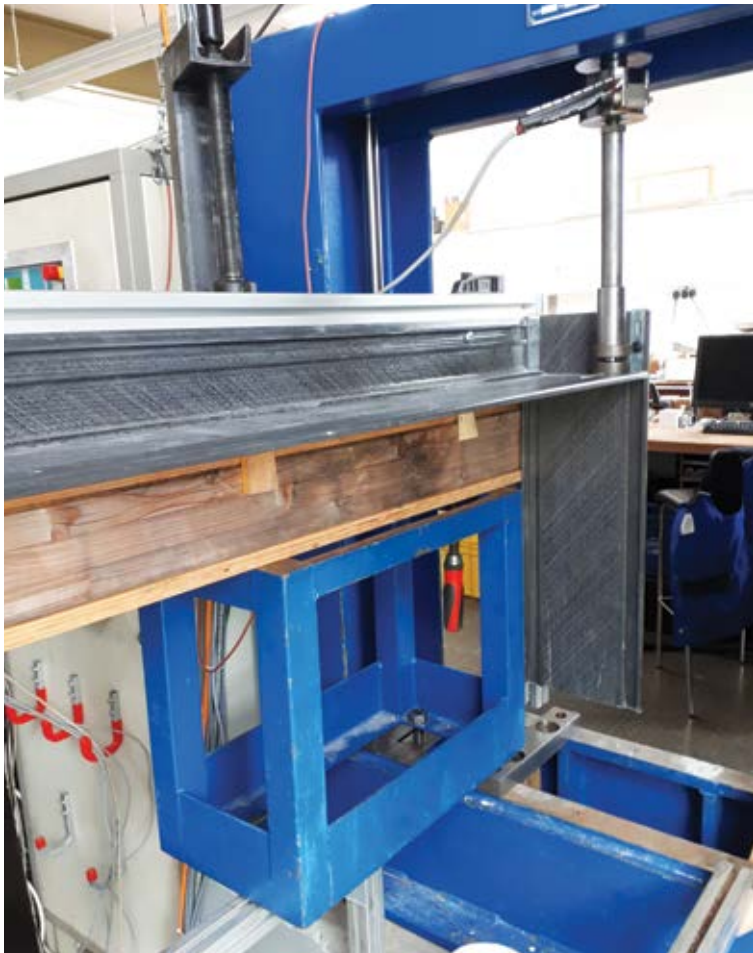
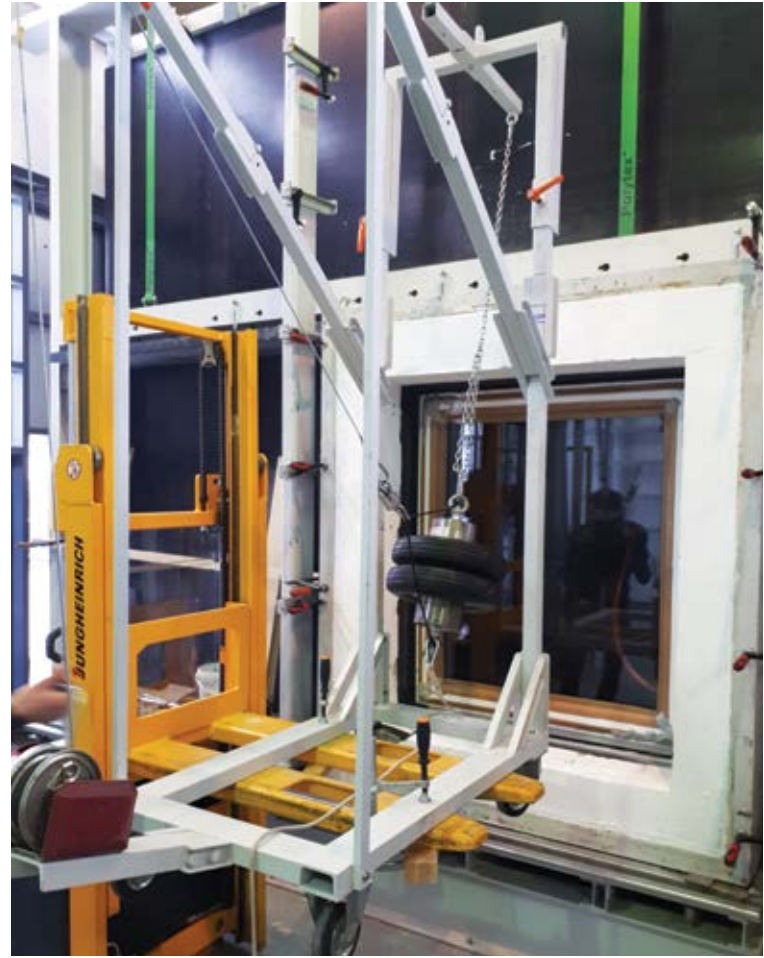

TESTED & APPROVED



CERTIFIED QUALITY

Trust is good, control is better!

TECHNICAL SPECIFICATIONS Soudaseal SWI

Soudaseal SWI is a high-quality, neutral, elastic and one-component adhesive and sealant based on hybrid polymer with a very high initial tack. Soudaseal SWI was specially developed for bonding and air- and watertight sealing of the SoudaFrame

SWI pre-wall mounting system. Adheres to most common building materials. Seal the corners of SoudaFrame SWI on the inside of the pre-assembled sub-frame.

TECHNICAL DATA	STANDARD	PROPERTIES
Basis		Hybrid polymer
Consistency		Stable paste
Curing system		Moisture curing
Skin formation* (23°C/50% R.H.)		ca. 5 min
Curing speed* (23°C/50% R.H.)		3 mm/24St
Hardness**		50 ± 5 Shore A
Density**		1,47 g/ml
Elastic recovery (ISO 7389)**	EN ISO 7389	> 75 %
Maximum allowed distortion	EN ISO 11600	± 20 %
Max. tension (ISO 37)**	EN ISO 37	3,00 N/mm ²
Elasticity modulus 100% (ISO 37)**	EN ISO 37	1,60 N/mm ²
Elongation at break (ISO 37)**	EN ISO 37	500 %
Consumption*		Approx. 7 m per foil bag of 600 ml (single bead with triangle nozzle)
Initial tack		Minimal 125 kg/m ²
Temperature resistance**		-40°C → 90°C
Application temperature		5°C → 35°C

* These values may vary depending on environmental factors such as temperature, humidity or type of substrate.

** The data refer to fully cured product.





WINDOW SEALING
EASY & RELIABLE



SEALING OF CONS- TRUCTION JOINTS

SOUDAL WINDOW SYSTEM

Sealing of the construction joints around windows



Top-grade elastic PU foam with outstanding filling and insulation characteristics combined with ease of use. Absorbs up to 50% of joint movement and thus guarantees a long lasting thermal and acoustic insulation. Specially developed for window installation in accordance with the EPD rules by avoiding thermal bridges. Very precise

dosing, little to no post-expansion and therefore extremely economic in use. Fast skin formation and curing, which results in shorter waiting times. Can also be used in winter at below 0°C temperatures. Recognisable blue colour. Very low emission (EC-1 Plus). Available in screw thread and Click & Fix®.

PROPERTIES

3 times more flexible than a traditional PU foam	
High thermal insulation ($\lambda = 0,0345 \text{ W/m.K}$)	
Good acoustic insulation: $R_{ST,w} = 63 \text{ dB}$	
Water vapour permeable	
Fire reaction class B2	
Very good dimensional stability (no retreat or post-expansion)	
EC-1 PLUS VERY LOW EMISSION	
Tested according to ift guideline MO-01/1, MO-02/1 Wall connection of windows	



**FLEXIBLE
THERMAL INSULATION
ACOUSTIC INSULATION**

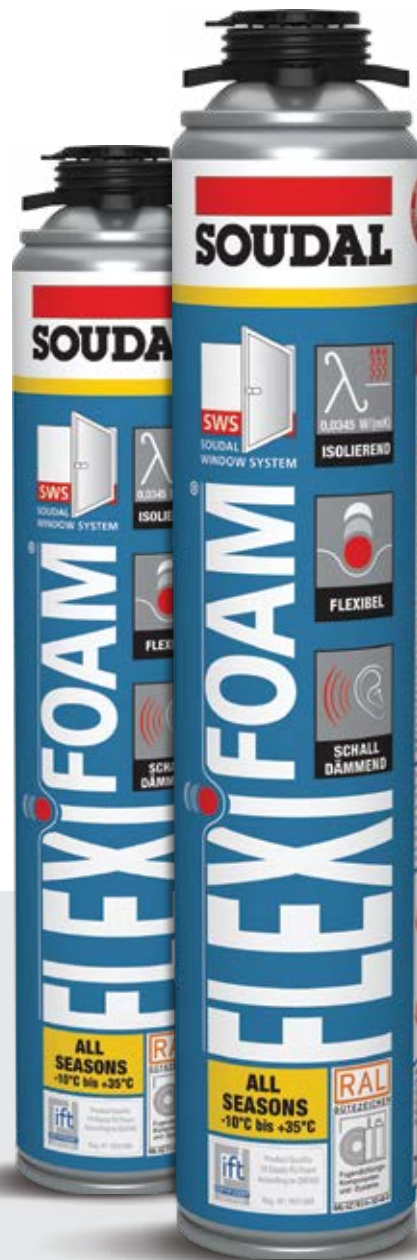

SOUDAL WINDOW SYSTEM

Sealing of the construction joints around windows



SOUDATIGHT LQ/SP **SPRAY & BRUSHABLE AIR- AND VAPOUR TIGHT** **LIQUID MEMBRANE**

Soudatight LQ / SP is a high-quality waterbased polymer paste that, after drying, forms a seamless, air- and vapour tight elastic membrane. For the air- and vapour tight sealing of ducts, window connections, wall, floor-wall and wall-ceiling connections and roof connections. Soudatight LQ / SP can be applied in the desired layer thickness on almost all mineral surfaces.

Soudatight SP is the airless spray version for the bigger, more professional applications, where Soudatight SP GUN can be used i.c.w. a pneumatic gun and a compressed air for the smaller jobs. Fiber reinforced, Soudatight LQ is able to bridge or fill cracks up to 2 mm.



PROPERTIES

Airtight and vapour retardant

Fiber reinforced for crack bridging:
sealing cracks up to 2 mm (Soudatight LQ)

Vapour diffusion resistance factor (μ value): 10241

Equivalent air layer thickness (Sd value): 10,96 m

Can be painted or plastered over

Permanently elastic after curing and extremely durable

Temperature resistant from -20 ° C to +80 ° C

EC-1 PLUS
VERY LOW EMISSION



Excellent adhesion to many porous materials, even slightly damp ones

Tested according to ift guideline MO-01/1, MO-02/1 Wall connection of windows



AIRTIGHT
VAPOUR TIGHT
ELASTIC

SOUDAL WINDOW SYSTEM

Sealing of the construction joints around windows



EXT

EXTERIOR

SOUDATIGHT HYBRID

SPRAY & BRUSHABLE AIR- AND WATERTIGHT LIQUID MEMBRANE

Soudatight Hybrid is a high-quality hybrid polymer paste that, after drying, forms a seamless air- and watertight elastic membrane. For in- and outdoor applications. Soudatight Hybrid is used for the air- and watertight sealing of penetrations, window connections, floor-wall connections

and wall-ceiling connections. Soudatight Hybrid, packaged in a 600 ml foil bag, can also be applied with a pneumatic gun (Jetflow 3 Foil Bag 600) as a bead or sprayed as a coating.

PROPERTIES

Air- and driving rain tight and vapour permeable

Can be applied in a bead or sprayed on as a coating by means of a special pneumatic gun

Vapour diffusion resistance factor (μ value): 1464

Equivalent air layer thickness (Sd value): 1,4 m

Can be painted or plastered over

Permanently elastic after curing and extremely durable

Temperature resistant from -40 ° C to +90 ° C

EC-1 PLUS
VERY EMISSIONS ARM



Tested according to ift guideline MO-01/1, MO-02/1 Wall connection of windows



AIRTIGHT
DRIVING RAIN TIGHT
ELASTIC

NOTES DRAWINGS

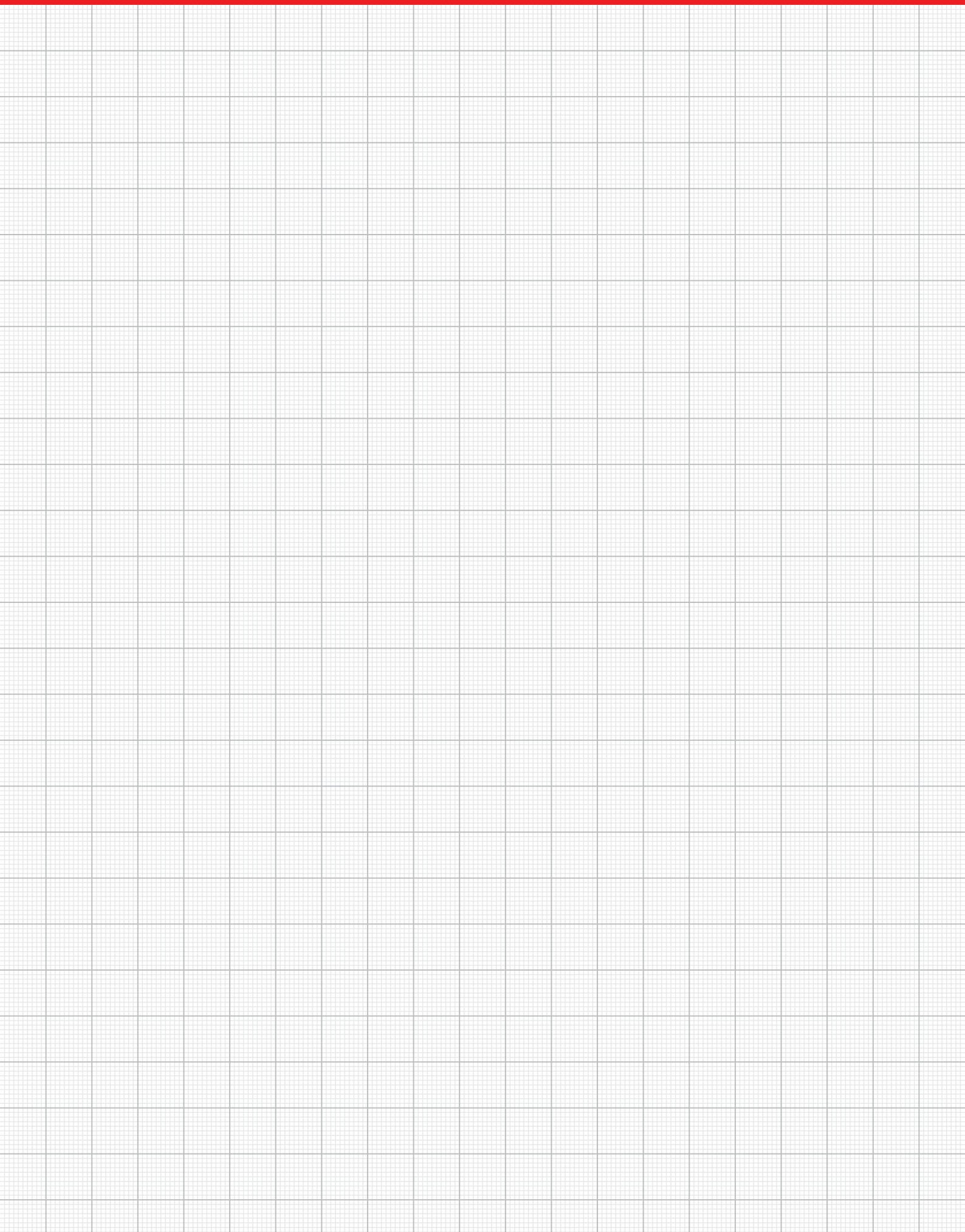



THE PRE-WALL WINDOW INSTALLATION SYSTEM

SWI SOUDAFRAME



Your distributor

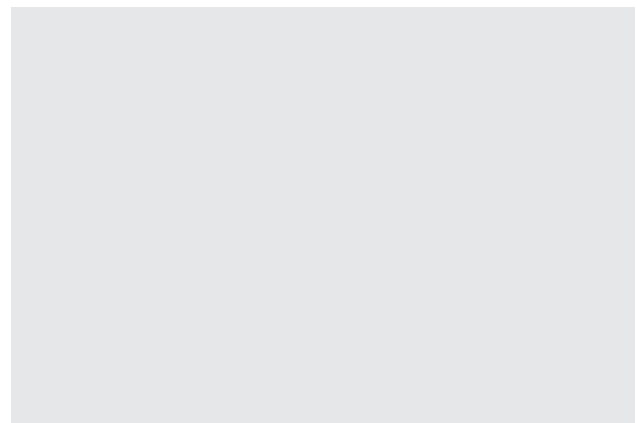

SOUDAL N.V.
Everdongenlaan 18
2300 Turnhout
Belgium
Tel: +32 14 44 78 78
www.soudal.com